

GREASE SEPARATOR SILT STORAGE V100 - SIZE 1-2 ABOVE GROUND INSTALLATION AND DOOR PASSAGE IN POLYETHYLENE

ENPBI

6611



Installation

The device is installed on the level and as close as possible to the place to be treated. It will be installed above ground on a perfectly flat and smooth surface on the entire surface of the device. Manhole(s) always remain accessible for maintenance. We recommend a minimum diameter of 50 for aeration pipe which will be equipped with a device preventing the passage of insects and small animals.

**20 YEAR
WARRANTY
AGAINST
CORROSION**

CE
EN 1825-1

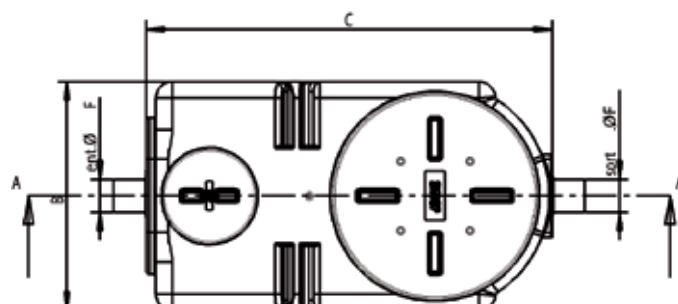
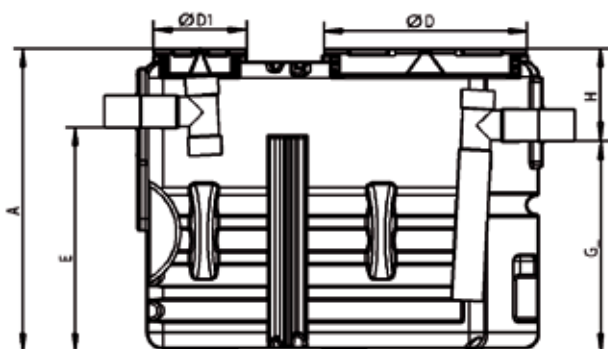

Extraction device ND 80 (OD2/109), on right wall flow direction. *Option*
Grease level alarm, see page 28. *Option*

Reference	Size	A	B	C	D	D1	E	F	G	H	Silt storage Volume	Separator Volume	Extraction Device
SG2/6611/01	1	1060	700	1246	625	287	815	110	745	315	100	380	OD2/109
SG2/6611/02	2	1060	700	1827	625	635	815	110	745	315	200	515	OD2/109